

BUILD DETAILS	
ITEMS	VALUE
MODEL	XTR 1860
LENGTH	15'
WIDTH	60"
ENGINE	170/300 HP, ROTAX
BOTTOM THK	0.190
COLLAR MATERIAL	GREY URETHANE
COLLAR PRESSURE	2.5 PSI
FUEL CAPACITY	27 GAL.
BOW STORAGE	STANDARD
STOMP GRATE	STANDARD
BOTTOM UHMW	YES
SIDE UHMW	YES
AQUATRACON COLOR	TBD
BOW COOLER/SEAT	NO
TRAILER	CUSTOM, DUAL

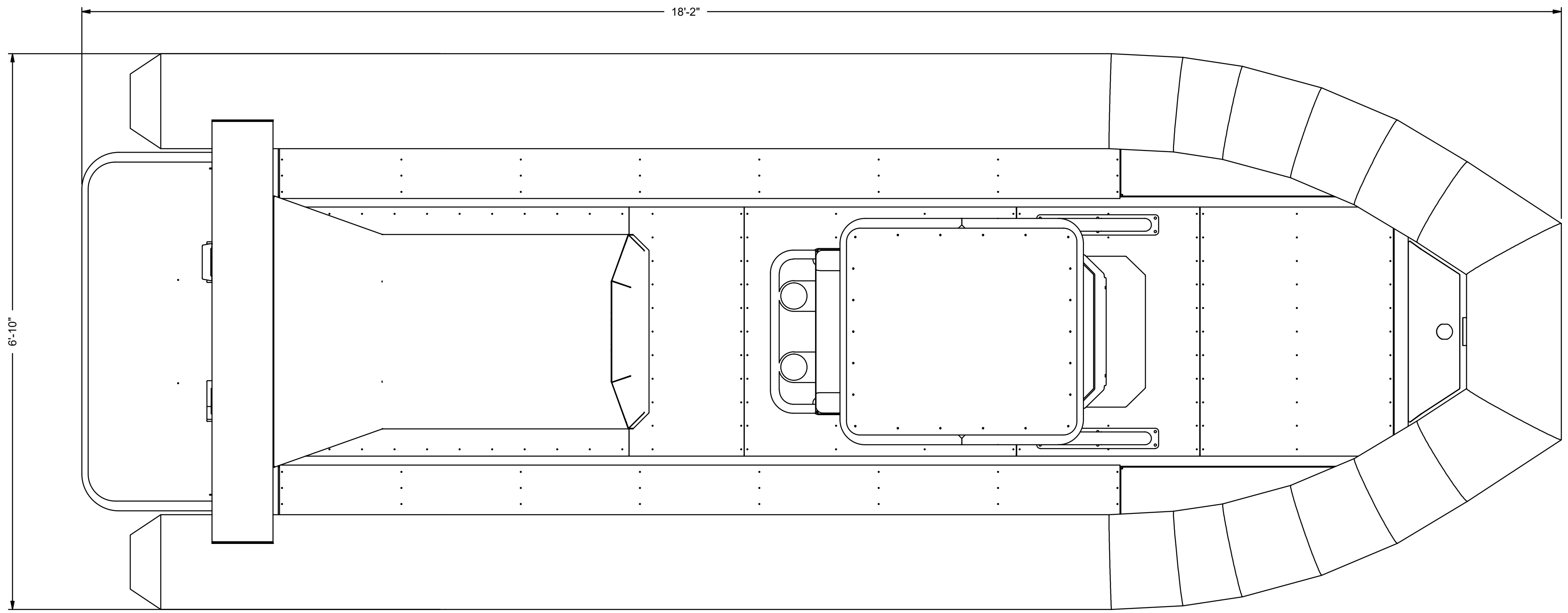

**TOP VIEW**  
SCALE 1:12

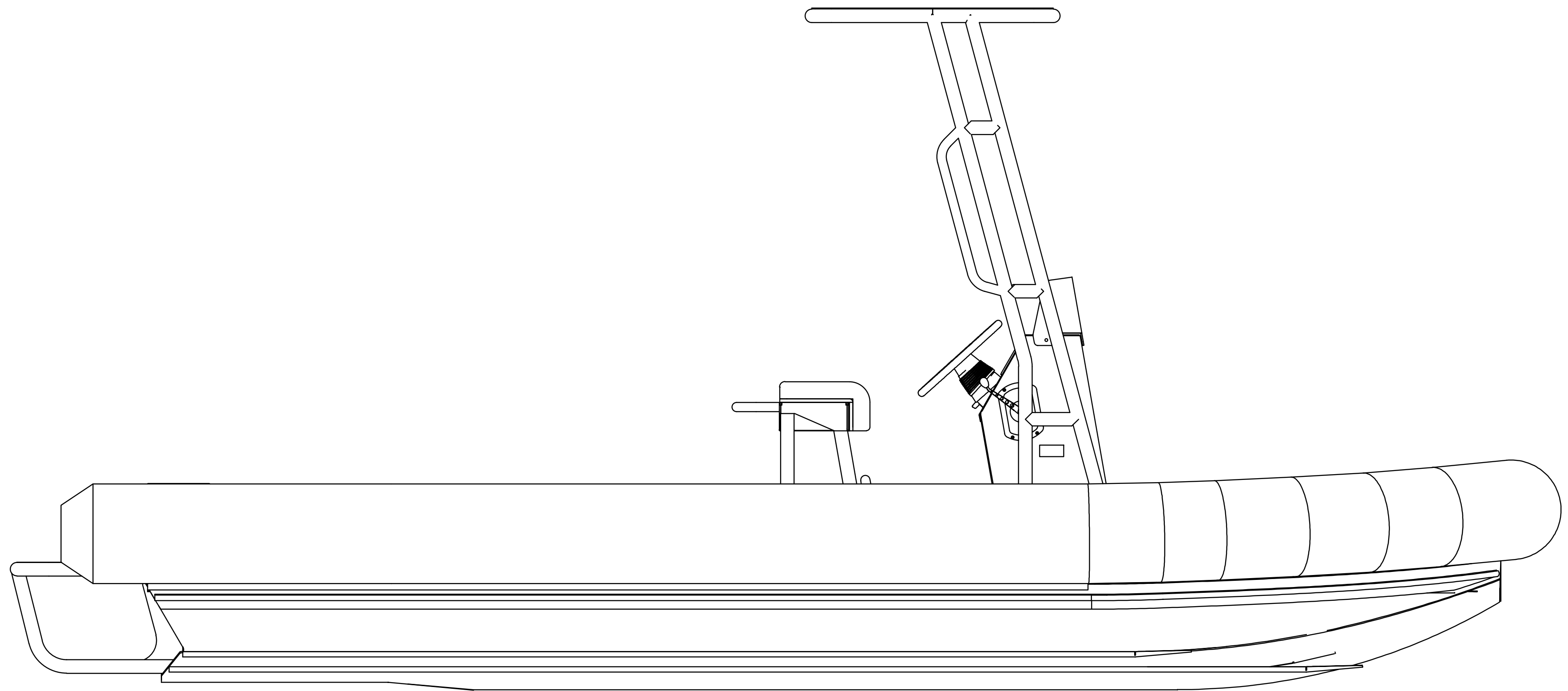

**SIDE VIEW**  
SCALE 1:12

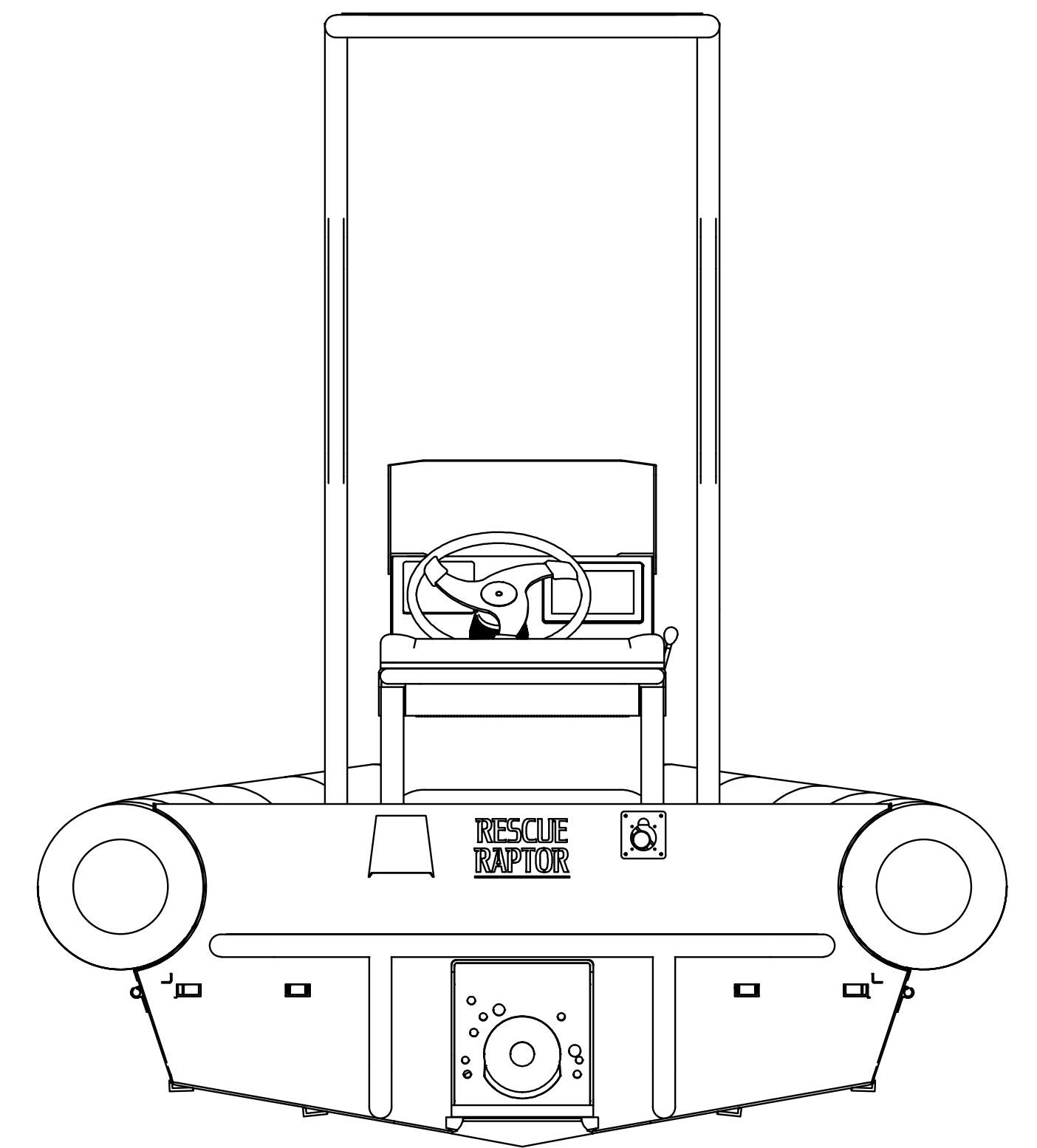

**REAR VIEW**  
SCALE 1:12



1860 XTR FORWARD CONSOLE  
SCALE 1:8

<small>THIS DRAWING IS THE PROPERTY OF RAPTOR DESIGN AND ENGINEERING AND SHALL NOT BE USED OR COPIED EXCEPT AS EXPRESSLY AUTHORIZED. ANY ABUSE OF THIS INFORMATION IS STRICTLY FORBIDDEN AND THE DESIGNER SHALL BE LIABLE FOR ANY AND ALL DAMAGES SUFFERED AS A RESULT.</small>		<small>UNLESS OTHERWISE NOTED, DIMENSIONS SHALL BE IN INCHES AND DECIMALS THEREOF. DIMENSIONS SHALL BE TO UNLESS OTHERWISE SPECIFIED. DIMENSIONS SHALL BE TO UNLESS OTHERWISE SPECIFIED. DIMENSIONS SHALL BE TO UNLESS OTHERWISE SPECIFIED.</small>		DRAWN BY RPlank	CREATED 11/22/2019	WEIGHT X LBS	DRAWING NUMBER <b>D0146</b>	REVISION 	DESCRIPTION XTR 1860
		CHECKED BY RPlank	ISSUED AS SHOWN	PART NUMBER D0146-1860XTR	SHEET 27 OF 29			<b>RAPTOR</b> DESIGN & ENGINEERING	

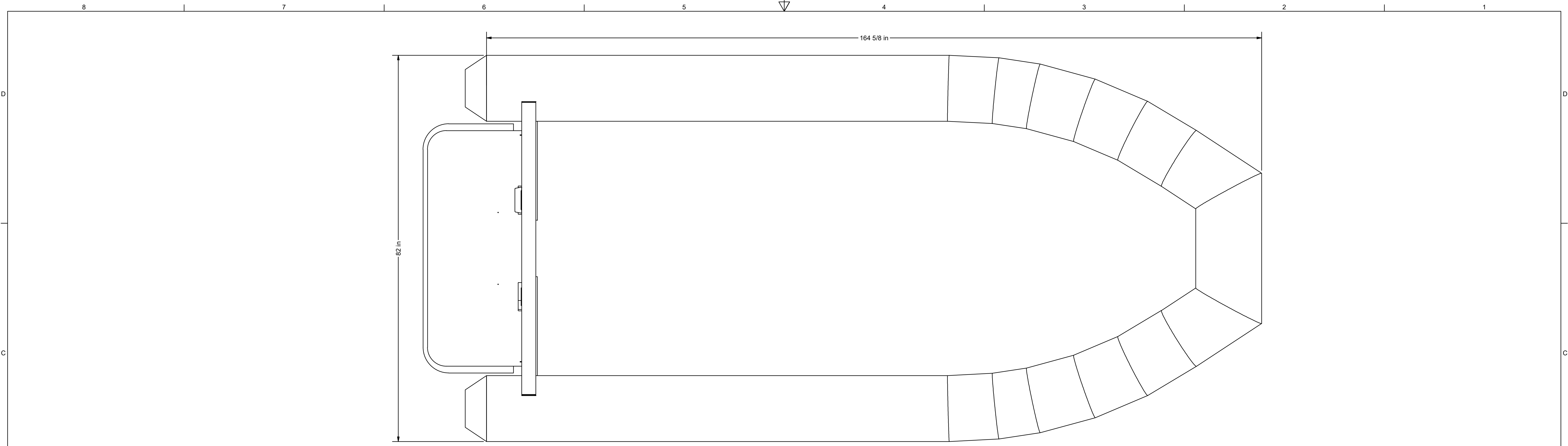

**15' MODEL**  
SCALE 1:10

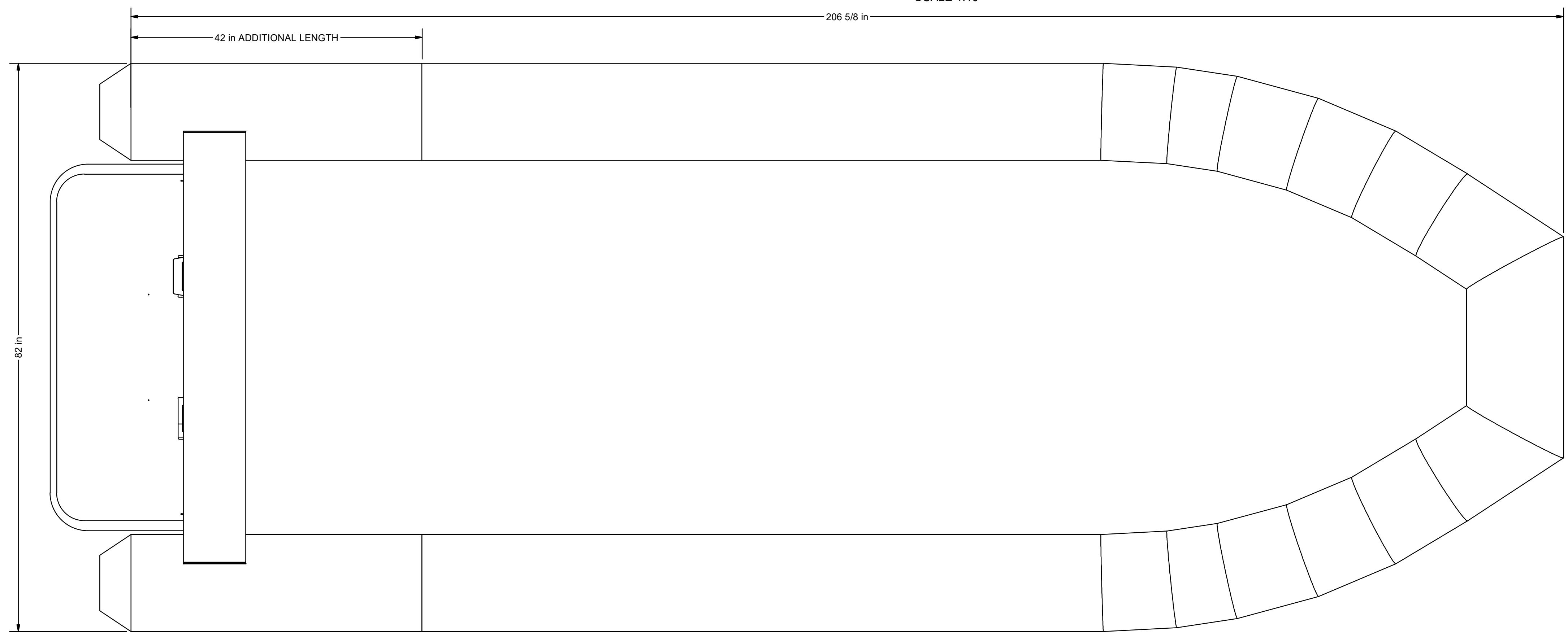

**18' MODEL**  
SCALE 1:10

<small>THIS DRAWING IS THE PROPERTY OF RAPTOR DESIGN AND ENGINEERING AND SHALL NOT BE USED OR COPIED EXCEPT AS EXPRESSLY AUTHORIZED. ANY ABUSE OF THIS INFORMATION IS STRICTLY FORBIDDEN AND THE USER SHALL BE LIABLE FOR ANY AND ALL DAMAGES SUFFERED AS A RESULT.</small>		<small>UNLESS OTHERWISE NOTED, DIMENSIONS ARE IN INCHES UNLESS OTHERWISE SPECIFIED. TOLERANCES ARE AS SHOWN.</small>		DRAWN BY <b>RPlank</b>	CREATED 11/22/2019	WEIGHT X LBS	DRAWING NUMBER <b>D0146</b>	REVISION 	DESCRIPTION XTR 1860
		CHECKED BY <b>RPlank</b>	ISSUED 	SCALE AS SHOWN	PART NUMBER D0146-1860XTR	SHEET 28 OF 29	D		