

FACTORY STOCK #3 NWCg TYPE 5 RESCUE SIDE WILDLAND ENGINE SKEETER EMERGENCY VEHICLES

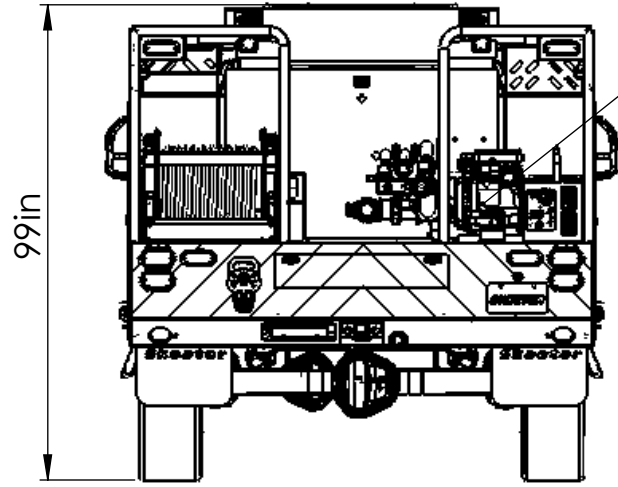

Darley 2BE 23V
w/Control Panel

99in

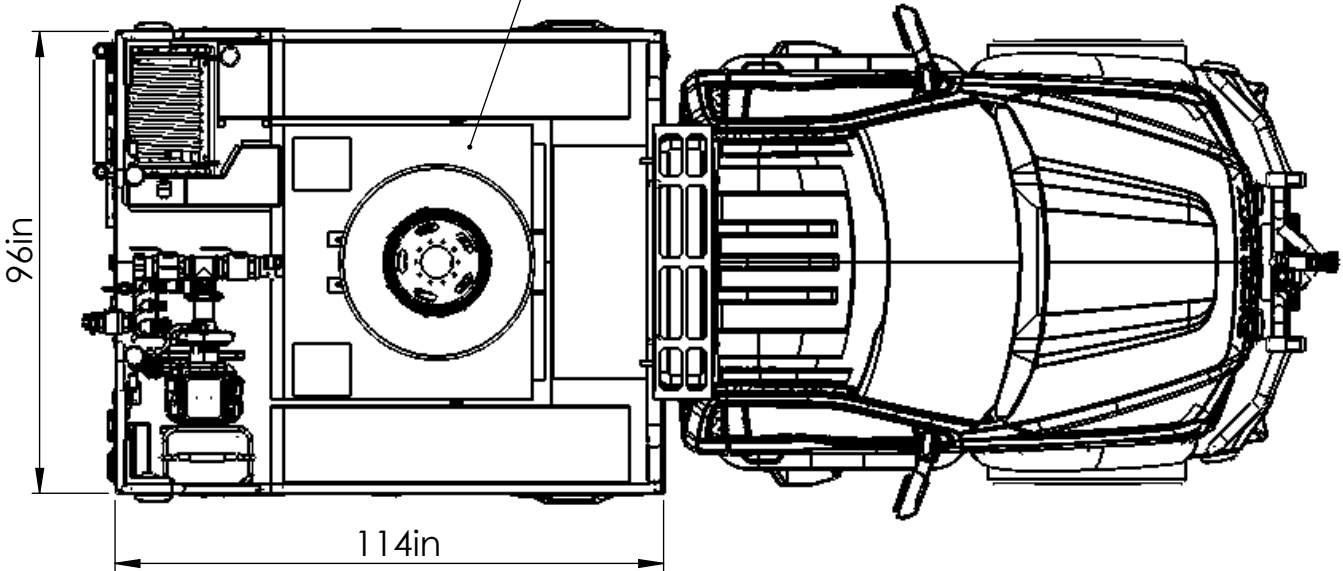

400 Gallon Water Tank
w/ 10 Gallon Foam

96in

114in

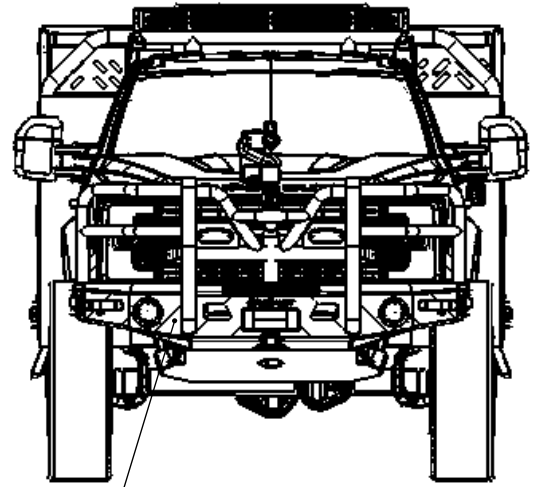

5' 10"



Custom Skooter Bumper
w/ Off-Road Lights, Winch,
Ground Sweeps, Monitor and
20" Scene Light

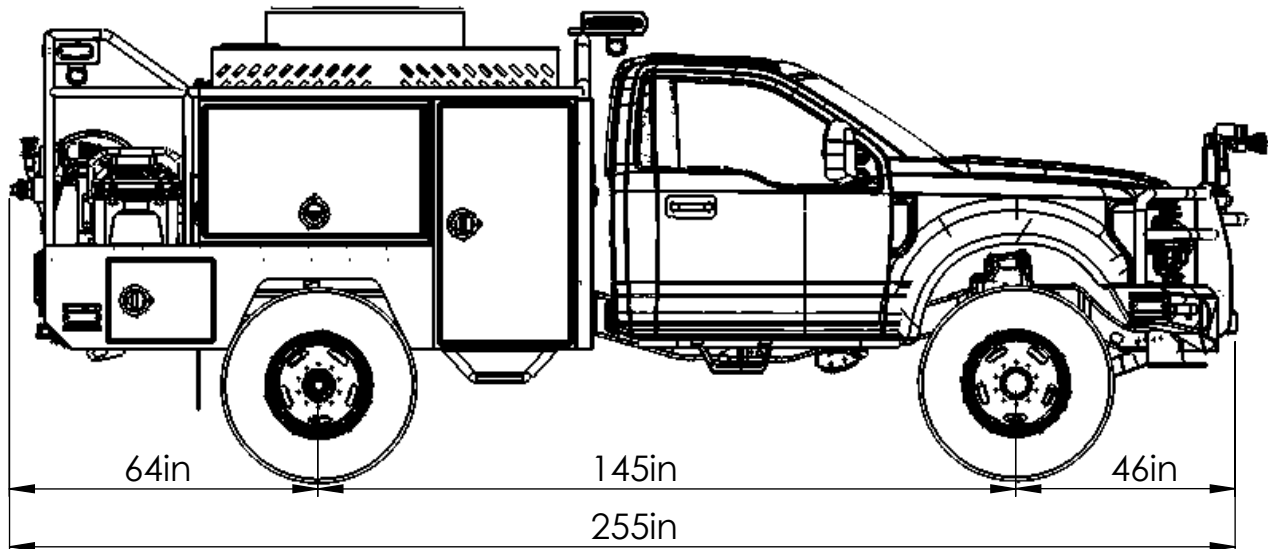

64in

145in

46in

255in

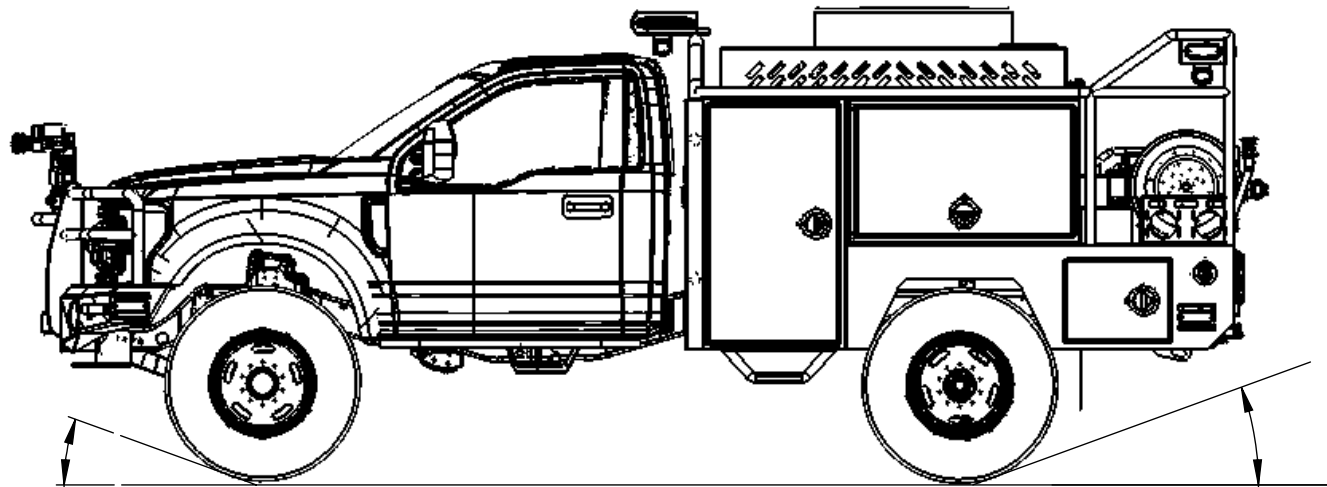

20deg
NFA MIN.

20deg
NFA MIN.

PROPERTY OF
SKEETER EMERGENCY VEHICLES

NOT FOR PRODUCTION. SOME FEATURES AND DIMENSIONS SUBJECT TO CHANGE

NOTE: DETAILS AND DIMENSIONS SHOWN ARE APPROXIMATE
AND ARE SUBJECT TO MINOR DEVIATIONS AS MAY
OCCUR OR BE NECESSARY IN CONSTRUCTION
MINOR DETAILS NOT SHOWN

PREPARED FOR:
FACTORY STOCK #3

DRAWN BY: ALONDRA P.
SPEC DATE: 4/30/25

TITLE:
PRELIMINARY OVERVIEW

SPEC # 2147

SHEET 1 OF 1